

Product data sheet

✉ sales@brannan.co.uk

☎ +44 (0)1946 816600

🌐 brannan.co.uk

WT025 - 5" INDUSTRIAL LIQUID-IN-GLASS THERMOMETERS



Product features:

- Heavy duty protective case with glass tube thermometer
- **Brannan** quality and accuracy
- Straight or angled connection
- Dual Scale
- For hot water and chilled water systems

Standard product specifications:

Scale	5" (127mm)
Case	Black aluminium (plastic available on request)
Design	ASME B40.200
Tube	Triangle tube with blue liquid filling
Window	Glass
Form	Bottom or 90° angle
Connection	1/2", 3/4" BSP/NPT
Stem (insertion)	45mm
Pocket Material	Brass (lead free brass or SS available on request)
Ranges	-40 to +110°F&C through +50 to +400°F&C
Accuracy	+/- 2%
Protection	IP54

Product data sheet

✉ sales@brannan.co.uk

☎ +44 (0)1946 816600

🌐 brannan.co.uk

Dimensions

Bottom entry:

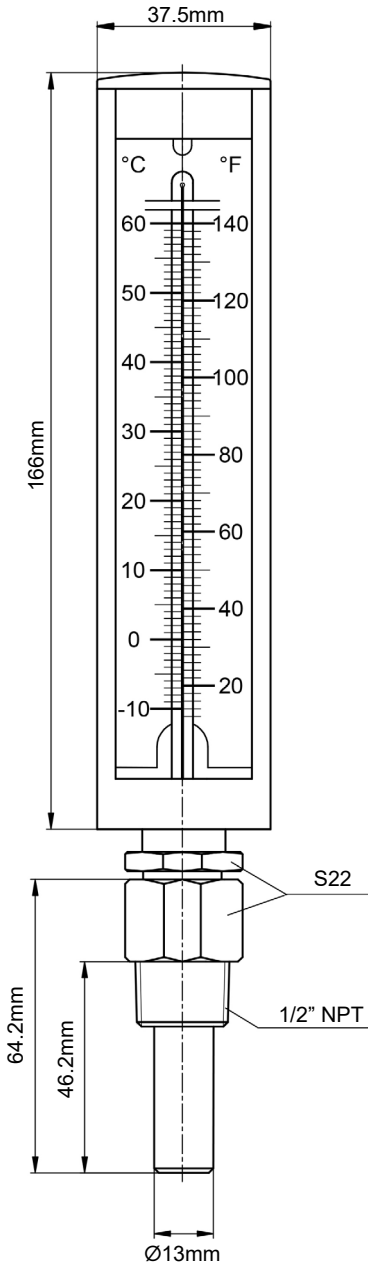

Back entry:

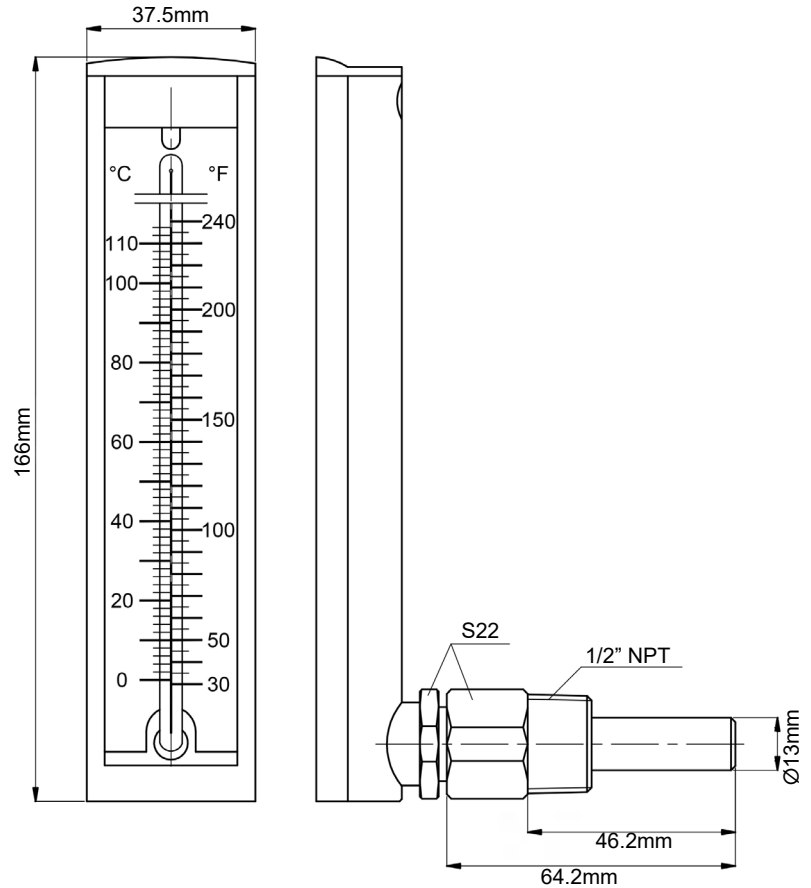

Standard product numbers (1/2" NPT connection):

Range	Product numbers	
	Straight case	Angled case
-40 to 110°F&C	200/701/0	200/801/0
20 to 180°F&C	200/702/0	200/802/0
30 to 240°F&C	200/703/0	200/803/0
30 to 300°F&C	200/704/0	200/804/0

Net weights:

Straight case: 246.0g

Angled case: 248.5g