

Product data sheet

✉ sales@brannan.co.uk

☎ +44 (0)1946 816600

🌐 brannan.co.uk

XT050 - SS PORTABLE LIQUID EXPANSION DIAL THERMOMETERS



Product features:

- Weatherproof thermometer with stainless steel case and bezel
- High quality liquid expansion measuring system
- 100mm diameter dial with robust handles and strong stainless steel stem
- Wide choice of temperature ranges and stem lengths
- **Brannan** quality and accuracy
- For outdoor applications

Standard product specifications:

Dial diameter	100mm
Design	BS EN 13190
Accuracy class	2
Ranges	0 to +100°C&F through to 0 to +300°C&F
Case	304 stainless steel
Bezel	304 stainless steel
Seal	74 shore D polyurethane
Stem lengths	400mm & 600mm
Sensor mechanism	Liquid expansion (Kerosene filling)
Window	Glass
Pointer	Black plastic
Filling	Dry
Operating temperature	0 to +40°C (higher or lower temperatures can cause indication errors)
Storage temperature	-40 to +60°C
Protection	IP67
Calibration	Certificate traceable to recognised national standard or statement of conformity, if required

Product data sheet

✉ sales@brannan.co.uk

☎ +44 (0)1946 816600

🌐 brannan.co.uk

Dimensions:

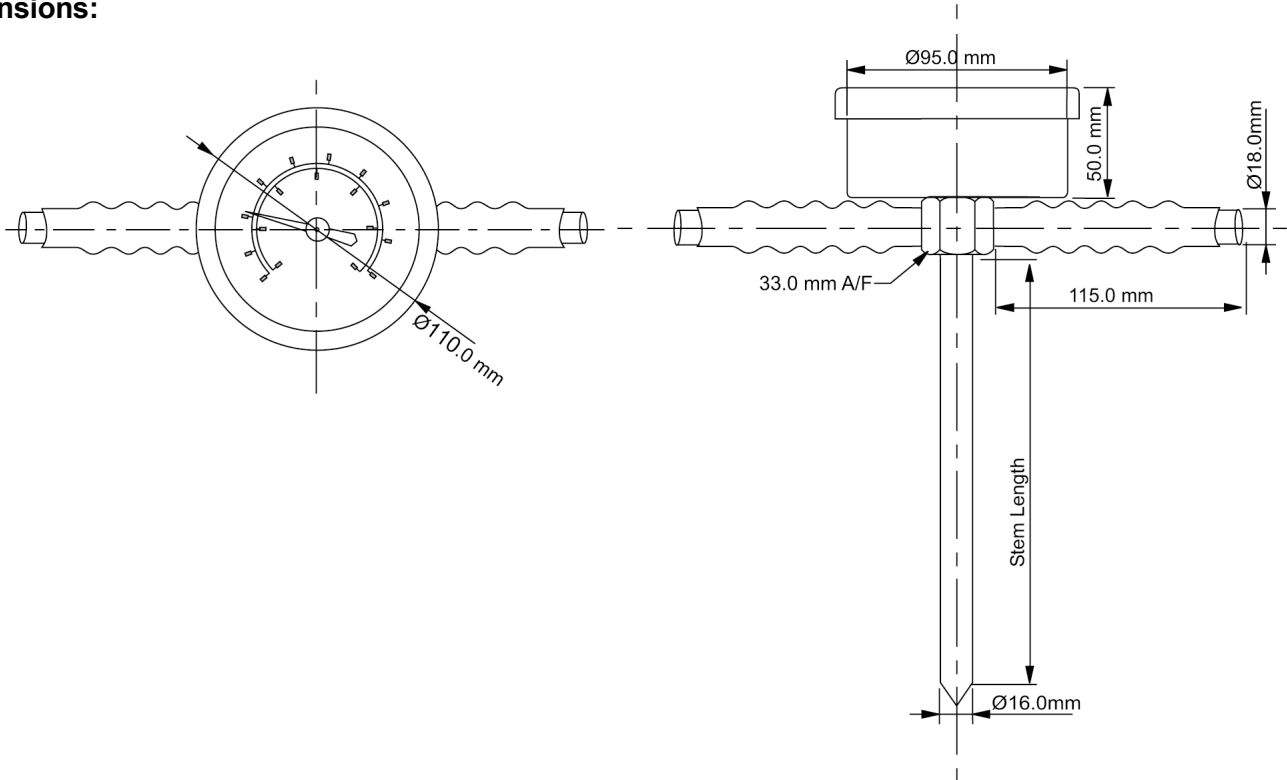

Standard product numbers:

The following are our standard product numbers for dial thermometers supplied complete with pocket. Special products can be supplied on request, for example, customer own branding, alternative pocket length, range, etc. Minimum order quantities apply. Please contact our Sales Team for further information.

Application	Stem length	Range	Product no
Silage	600mm	0 to 160°C&F	15/430/0
Asphalt/Bitumen	400mm	0 to 300°C&F	15/420/0
Asphalt/Bitumen	600mm	0 to 300°C&F	15/421/0
Concrete	400mm	0 to 100°C&F	15/431/0

Packaging:

All stainless steel expansion dial thermometers are supplied in individual box with specification label.

Product weight:
 400mm Thermometer: 1100g
 600mm Thermometer: 1180g

Dial face supplied protected by cardboard box (box weight: 45g)